

BRAKE BOOSTERS FORD

New Equipment By:
Bendix
Midland
Wagner
Delco

Rebuilt Equipment:
100% Factory Tested
Full Factory Warranty

FOR PARK BRAKES, SEE DRIVE LINE SECTION

HYDRO-MAX POWER BOOSTERS

Type 4

FOR FORD
CHASSIS

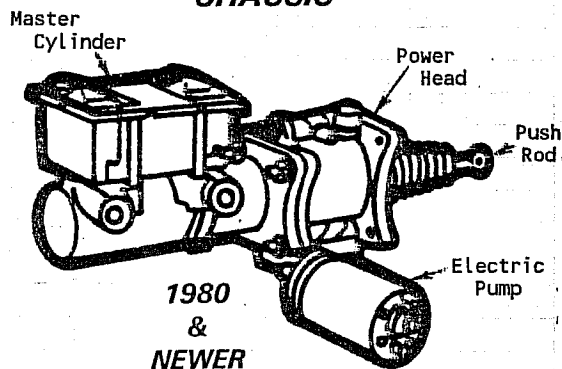

- LK2809 New Power Head
- LK2814 Rebuilt Power Head
- LK2835 New Electric Pump
- LK2837 Rebuilt Electric Pump
- LK5155 O-Ring - Power Head to Elec Pump

- LK2575 Electronic Control Module
- LK2832 Relay For Electric Pump

- LK0867 Flow Switch
- LK0167 Hydraulic Hoses
- LK2527 Pressure Switch For Park Brake

- JK0729 Push Rod
- LK5154 Grommet For Push-Rod Installation
- LK0101 How To Remove Push-Rod

- LK2385 Kit - Power Head Rebuild
- LK8783 Power Head Rebuild Instructions

- LK7888 Hydro-Max Operation & Repair Guide

Hydro-Max Boosters became standard on Ford beginning in 1980.



BRAKE
PUMP

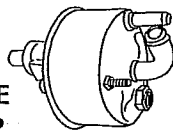

- LK3783 New
- LK3802 Reman

PARK BRAKE VALVE

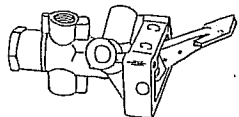

- LK1107 New
- LK1109 Rebuilt

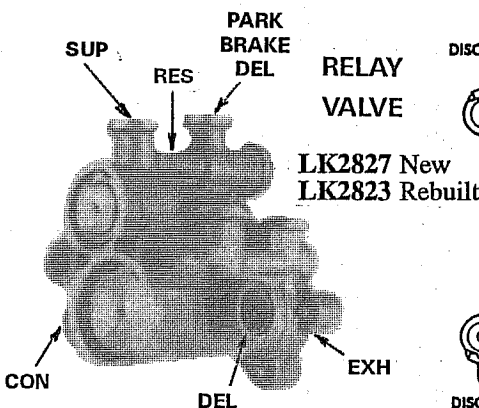

SERVICE INFORMATION



- LK5430 Troubleshoot Type-1 Booster
- LK0102 Remove Type-2 Push Rod
- LK0101 Remove Type-4 Push Rod
- LK8783 Rebuild Type-4 Power Head
- LK7888 Troubleshoot Type-4 System on Ford Bus Chassis

FIREWALL MOUNTED BOOSTERS

Type 2

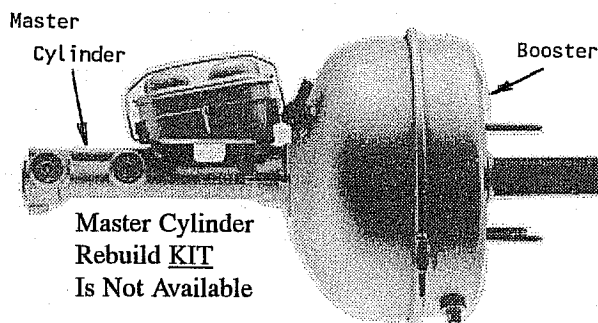

- LK2021 Rebuilt Master Cylinder Only

- LK2443 New Booster Only
- LK2010 Rebuilt Booster Only

- LK0102 How To Remove Booster Push-Rod

The Firewall Mounted Booster was used on Fords approximately 1968 thru 1977.

FIREWALL MOUNTED CHECK VALVES

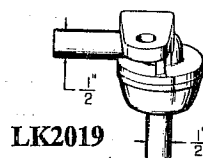
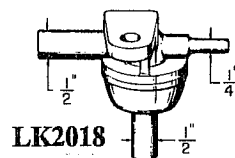

HYDRO-MAX BRAKE SCHEMATIC

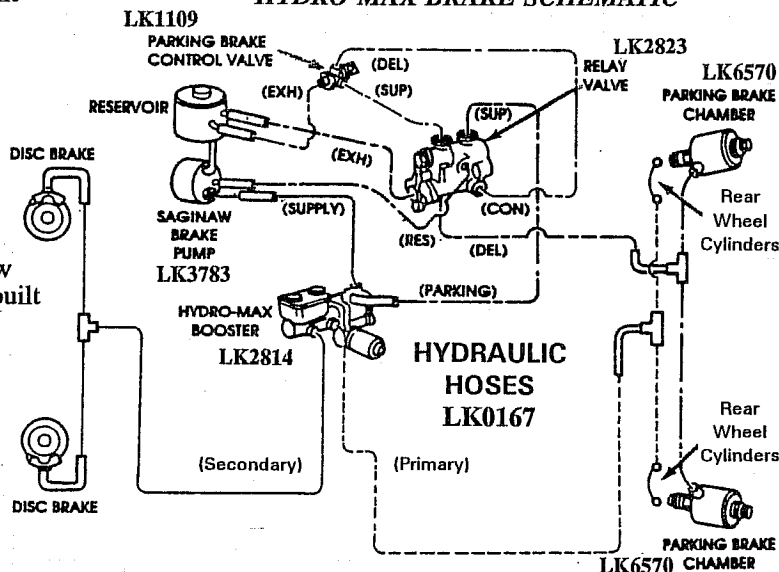

FRAME MOUNTED BOOSTERS

Type 1

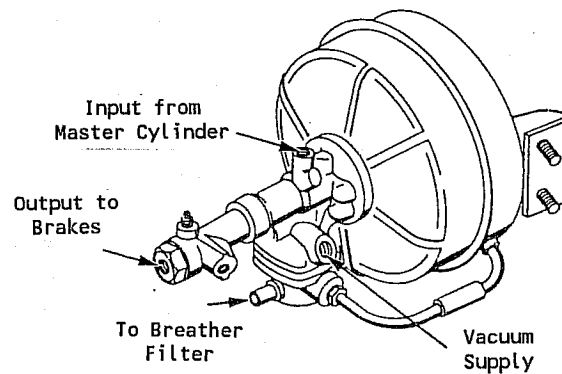

FOR FORD
CHASSIS

- LK2819 New Booster (FRONT)
- LK2006 Rebuilt Booster (FRONT)
- LK2474 New Booster (REAR)
- LK2007 Rebuilt Booster (REAR)

- LK2591 Brass Nipple For 3/8" NP Vacuum Port
- LK2594 Brass Nipple For 1/2" NP Vacuum Port

- LK2588 Adapter 5/16" IF Male / 1/4" IF Female
- LK2590 Adapter 1/4" IF Male / 5/16" IF Female

- LK5430 Booster Troubleshoot Guide

Dual Frame Mounted Boosters were used on Fords approximately 1968 thru 1979.

If your bus is equipped with only one frame mounted booster and was built between 1962 & 1967, use the booster designated as REAR (listed above).

DUAL BOOSTER COMBINATIONS

Type 6

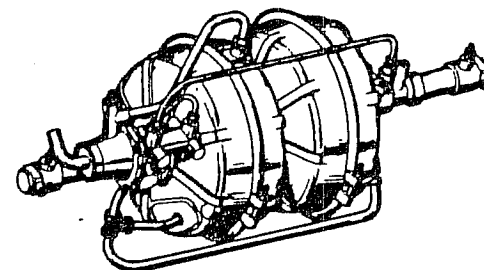

- LK2009 Reman Dual Booster

The "Duo-Vac" booster shown above was used on a few Fords between 1968 and 1973. This "Duo-Vac" system was different because two boosters were joined together at the base.

The combination booster shown above can be replaced with (2) individual units. Order (2) LK2048 reman boosters.

To make the switch, a few minor modifications to hoses, frame mounting, etc. must be made.

- LK5430 Booster Troubleshoot Guide